

PLAN
SCALE: 0 1 2 3 4 FT.

TYPE I

NOTE: ALL 4x4 POSTS TO BE FASTENED WITH 5/8x1/2" STEEL U-STRAP ANCHORS CAST INTO CONCRETE 12" ENDS TO EXTEND 12" ON SIDES OF POST. FASTEN WITH TWO 5/8x12 1/2" LAG SCREWS, STAGGERED, EACH SIDE. FOR OPENINGS UP TO 4'-0" USE TWO 2x4'S FOR OPENINGS UP TO 5'-6" USE TWO 2x6'S

COOPERATIVE EXTENSION WORK IN
AGRICULTURE AND HOME ECONOMICS
DEPARTMENT OF AGRICULTURAL ENGINEERING
UNIVERSITY OF MARYLAND
AND
UNITED STATES DEPARTMENT OF AGRICULTURE COOPERATING

STORAGE SHEDS

S.C. '69 6086 SHEET 1 OF 3

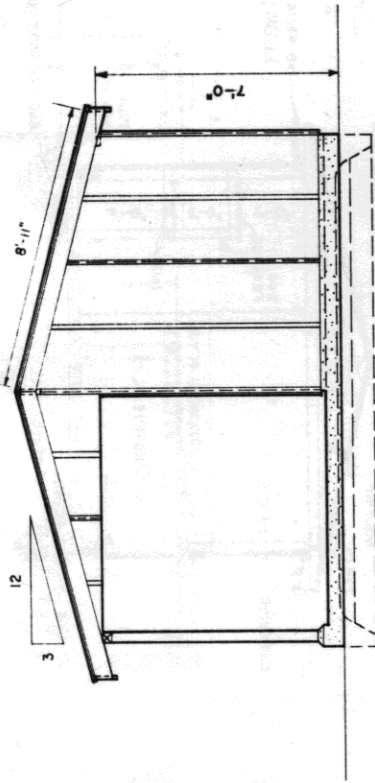

SIDE ELEVATION
SCALE: 0 1 2 3 4 FT.

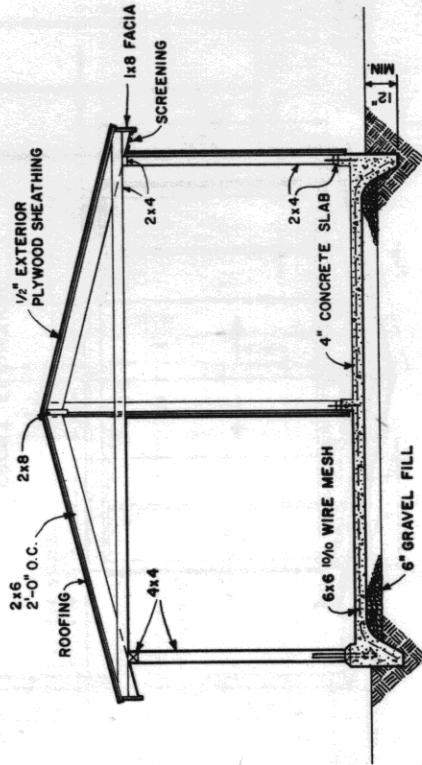

SECTION A-A
SCALE: 0 1 2 3 4 FT.

BASED ON: CLEMSON UNIV. S.C. PLAN 350

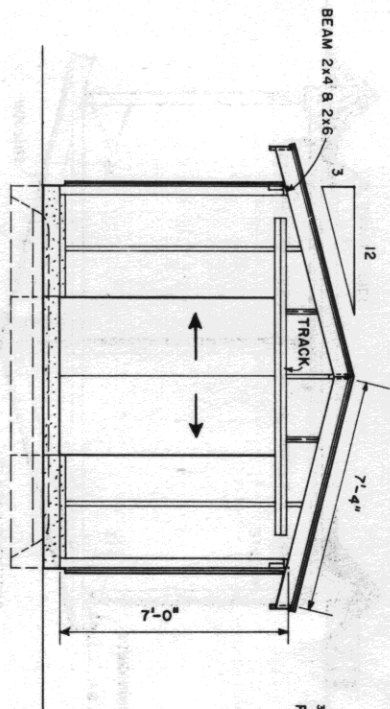

FRONT ELEVATION

SCALE: 0 1 2 3 4 FT.

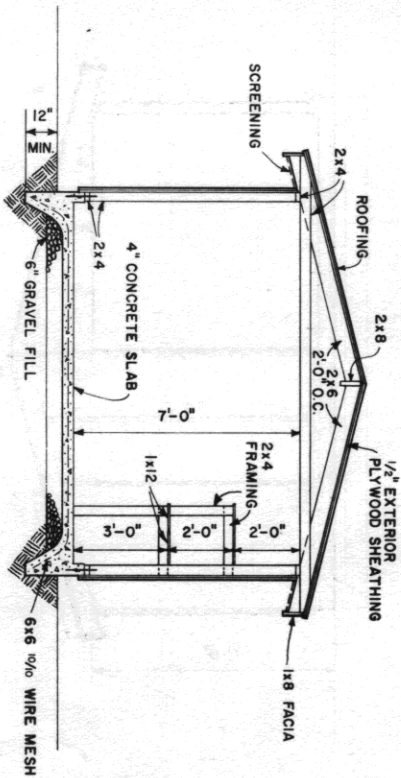

SECTION A-A

SCALE: 0 1 2 3 4 FT.

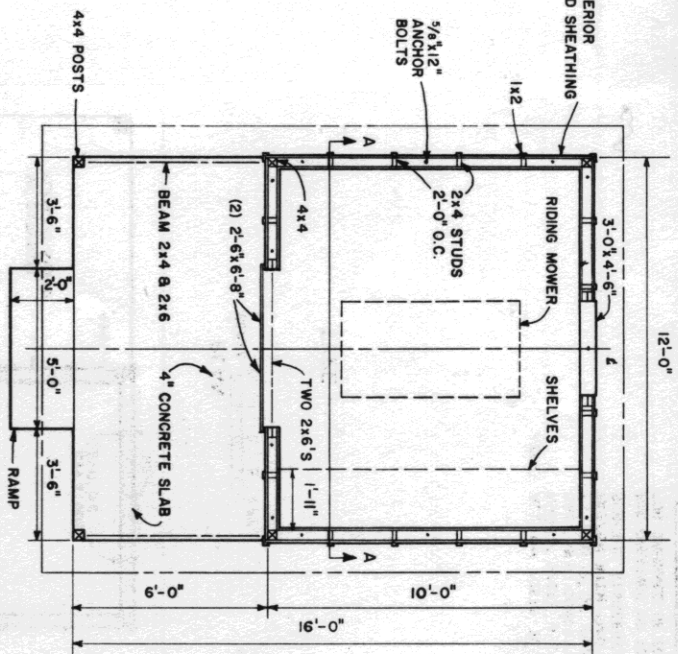

PLAN

SCALE: 0 1 2 3 4 FT.

TYPE 2

COOPERATIVE EXTENSION WORK IN
 AGRICULTURE AND HOME ECONOMICS
 DEPARTMENT OF AGRICULTURAL ENGINEERING
 UNIVERSITY OF MARYLAND
 AND
 UNITED STATES DEPARTMENT OF AGRICULTURE COOPERATING

STORAGE SHEDS

S.C. 69 6086 SHEET 2 OF 3

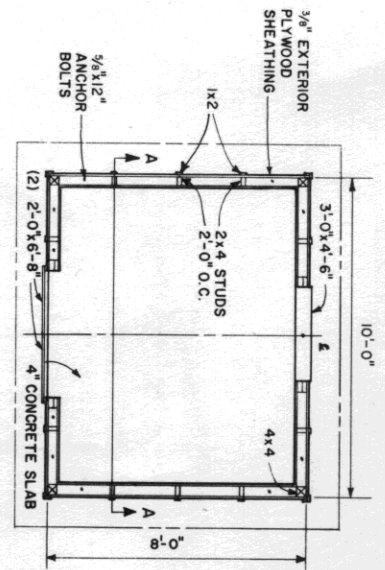

PLAN

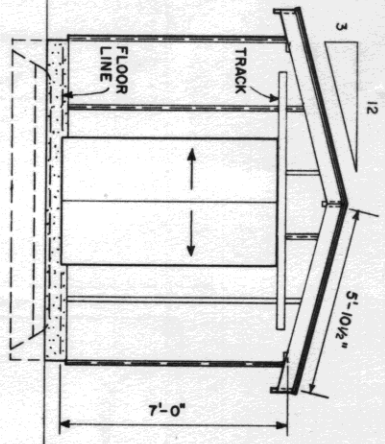

FRONT ELEVATION

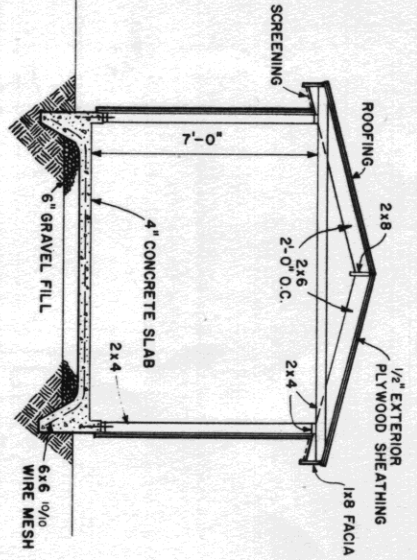

SECTION A-A

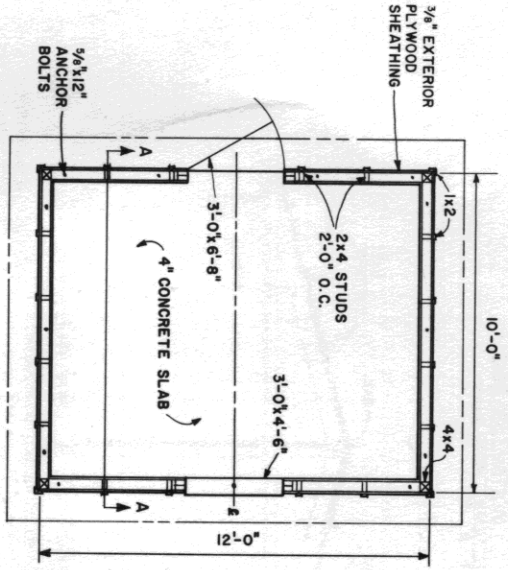
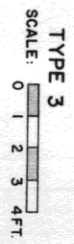

PLAN

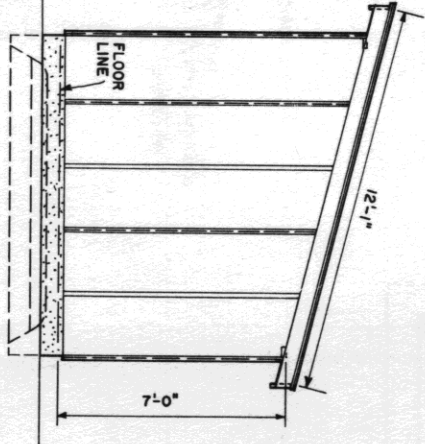

SIDE ELEVATION

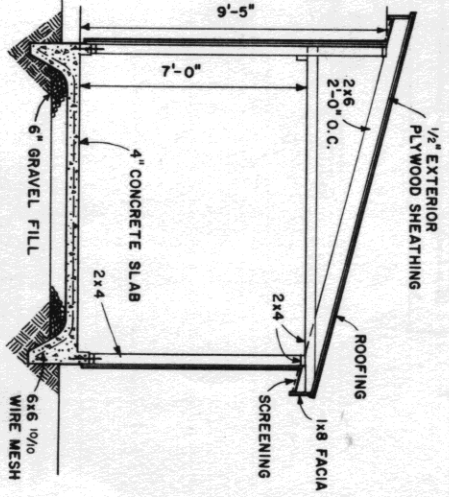

SECTION A-A

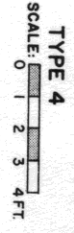

COOPERATIVE EXTENSION WORK IN AGRICULTURE AND HOME ECONOMICS DEPARTMENT OF AGRICULTURAL ENGINEERING UNIVERSITY OF MARYLAND AND UNITED STATES DEPARTMENT OF AGRICULTURE COOPERATING			
STORAGE SHEDS			
S.C.	'69	6086	SHEET 3 OF 3